

Innovative Low-cost 6-Axis F/T Sensor

RFT series is a capacitive F/T sensor that can measure the six components of force and torque simultaneously. The sensor has an innovative structure design and a robust calibration algorithm to achieve both of cost competitiveness and reliable performance. It provides users with various interface options to support a wide range of automation and research applications. It also has an internal overload protection to avoid damage from external impact or excessive load.



Capacitive Type

Sensing capacitance variation by structural deformation



High Durability

Mechanical overload protection, no adhesive



Low Cost

Simple structure, simplified fabrication process



Reliable Performance

Immunity to electrical noise, robust calibration, no sensor drift



Easy Installation All-in-one device with embedded signal processing, interface software support



Various Output Options

RS422, RS232, CAN, USB, and EtherCAT

Customization Service

User defined mechanical interface, Special specification

Applications

Force/torque monitoring & inspection, Force control of industrial robots and service robots, Force sensing in medical or rehabilitation devices, Haptic devices for teleoperation



RFT Series

- Compact Size Type
- Hollow Core Type
- Dust Seal Type
- High Resolution Type

SENSOR SPECIFICATIONS

Sensor Model	Dimension		Weight	Data Rate	Load Capacity			Resolution		
	∅	H	Except Cable	Maximum	Fx, Fy	Fz	Tx, Ty, Tz	Fx, Fy	Fz	Tx, Ty, Tz
	mm	mm	g	Hz	N	N	Nm	mN	mN	mNm
RFT80-6A02	80	30	294	1,000	400	400	20	80	80	4
RFT80-6A01	80	22	226	1,000	400	400	20	100	100	5
RFT64-6A01	64	30	175	1,000	200	200	10	80	80	4
RFT64-SB01	64	20	140	1,000	150	200	4	150	200	5
RFT60-HA01	60	18.5	120	1,000	150	200	4	150	200	5
RFT44-SB01	44	20	70	200	100	150	2.5	200	200	8
RFT40-SA01	40	18.5	60	200	100	150	2.5	200	200	8

Resolution : The standard deviation of each six components of force and torque for 10second, the data through internal 1st-order low pass filter which has cutoff frequency 100Hz

Sensor Model	Dimension		Hysteresis			Overload Capacity				Cross Talk		
	∅	H	Fx, Fy	Fz	Tx, Ty, Tz	Fx, Fy	Fz+	Fz-	Tx, Ty, Tz	Fx, Fy	Fz	Tx, Ty, Tz
	mm	mm	%FS			%				%FS		
RFT80-6A02	80	30	1	1.5	2	300	300	300	300	3	3	3
RFT80-6A01	80	22	2.5	1	1	150	200	400	200	3	3	3
RFT64-6A01	64	30	1	1.5	2	300	300	300	300	3	3	3
RFT64-SB01	64	20	3	2	2	150	150	300	150	3	3	3
RFT60-HA01	60	18.5	2.5	1	1	150	150	300	150	3	3	3
RFT44-SB01	44	20	2.5	1	3	150	150	300	150	3	3	3
RFT40-SA01	40	18.5	2	0.5	1	150	150	300	150	3	3	3

Fz+ : Tensile force, Fz- : Compressive force . The capacity of compressive force is more capacity than the capacity of tensile force

ORDERING INFORMATION

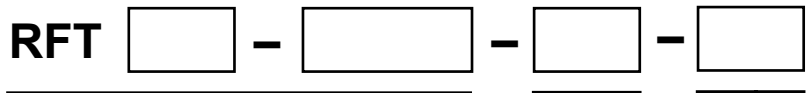

Sensor Feature

- RFT80-6A02 = ø80mm, High resolution, Temp. compensation
- RFT80-6A01 = ø80mm, High resolution
- RFT64-6A01 = ø64mm, High resolution, Temp. compensation
- RFT64-SB01 = ø64mm, Dust seal
- RFT60-HA01 = ø60mm, Hollow core
- RFT44-SB01 = ø44mm, Dust seal
- RFT40-SA01 = ø40mm, Solid core

Interface Method

- A = CAN
- B = RS-232
- C = RS-422
- D = USB
- E = EtherCAT (External board)
(Embedded for RFT80-6A02 and RFT64-6A01)

Cable Option

- “ ” = Default, Shielded, General signal cable, 2 meters
- R3 = Shielded, Robot cable, 3 meters
- R5 = Shielded, Robot cable, 5 meters

ROBOTOUS INC. Head office & Factory
2nd F, NEX-Center SKnTechnopark 124, Sagimakgol-Ro,
Jungwon-gu, Seongnam-si, Gyeonggi-do, KOREA
Tel:+82-31-606-9918 Fax:82-31-776-2645
Website: www.robotous.com
Contact: support@robotous.com

DIMENSIONS

RFT80-6A02

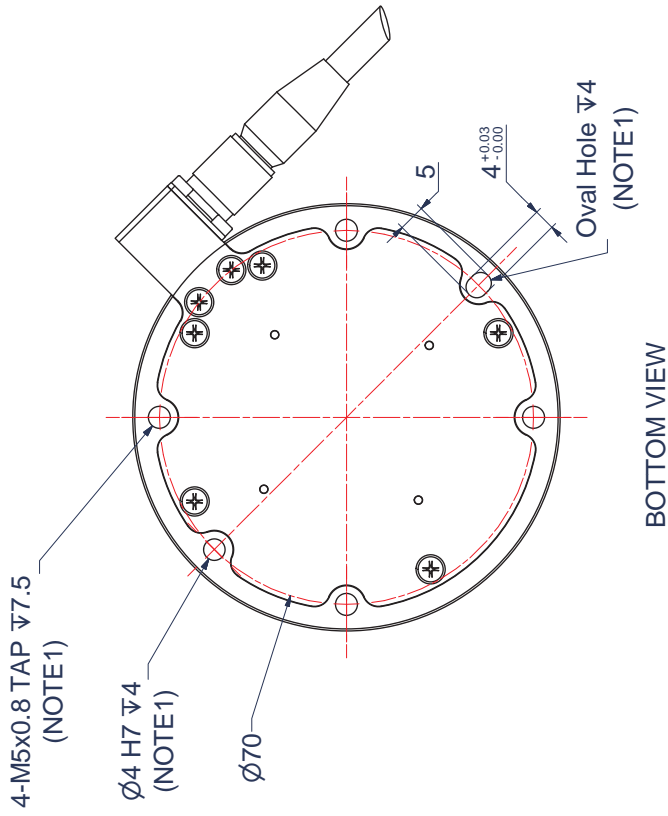
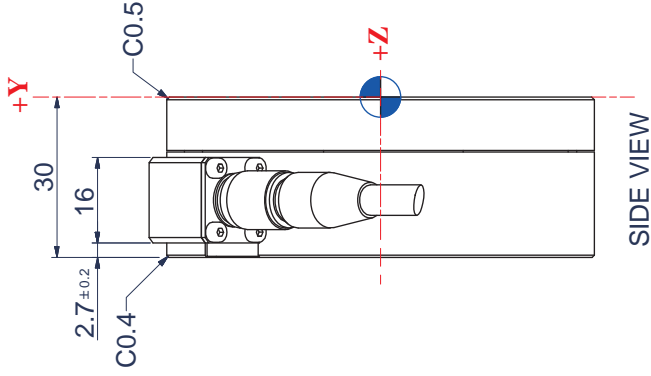
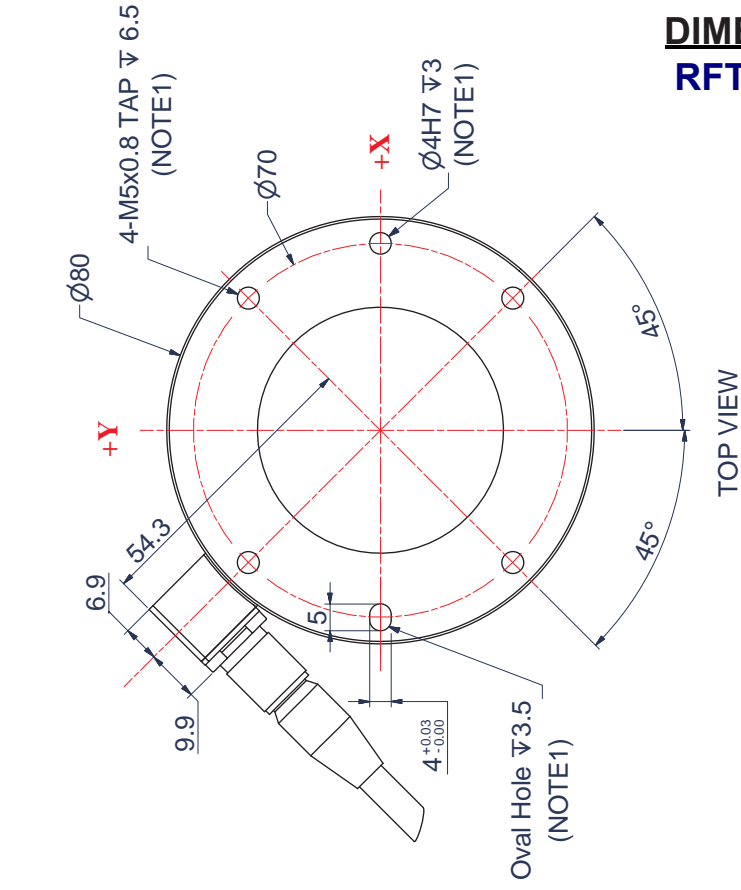

NOTES

1. Do not exceed interface depth, may cause damage.
2. Do not pull on a cable strongly.
3. The housing has been grounded to protect it from external electric noise

PROJECTION	DIMENSION	UNIT
		mm

DIMENSIONS

RFT80-6A01

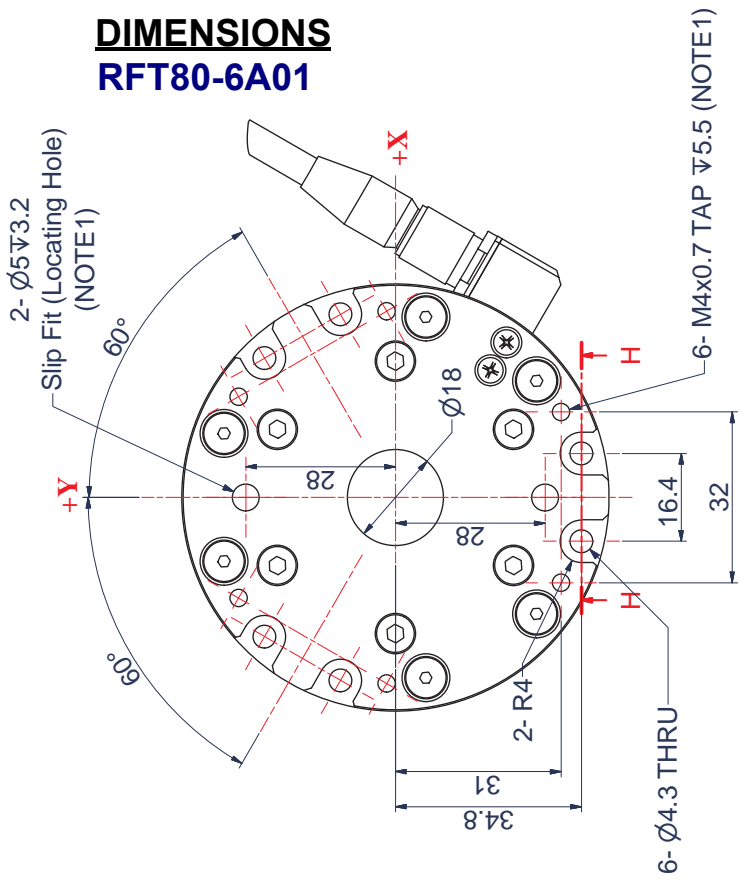

TOP VIEW

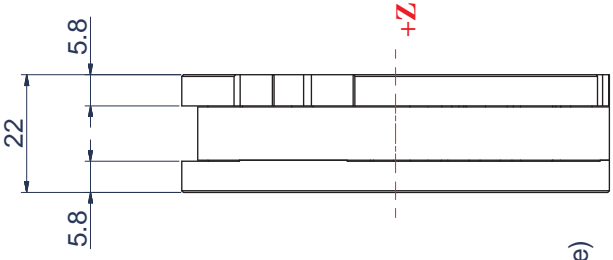

SIDE VIEW

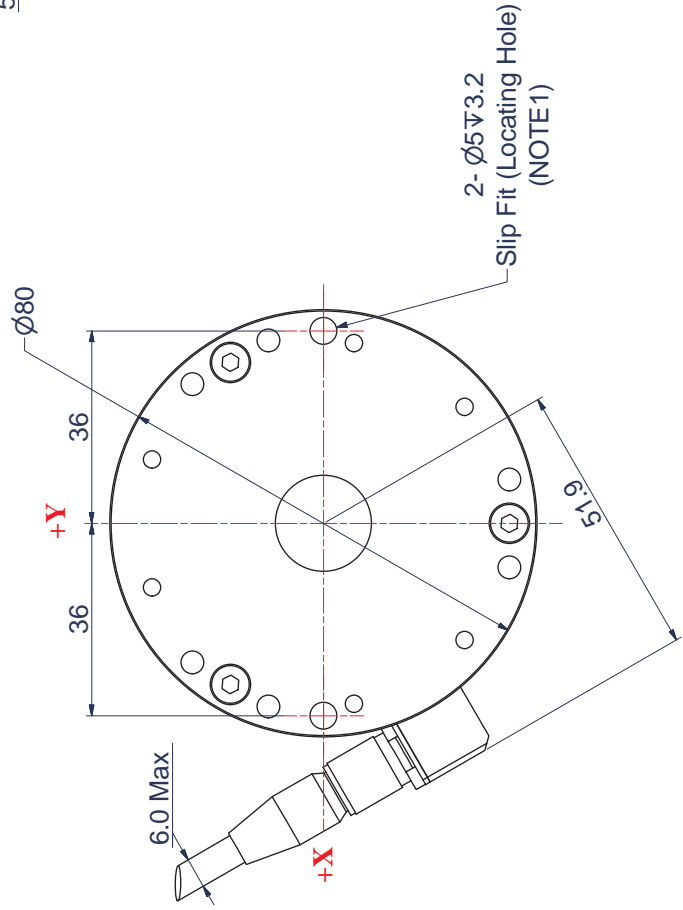

BOTTOM VIEW

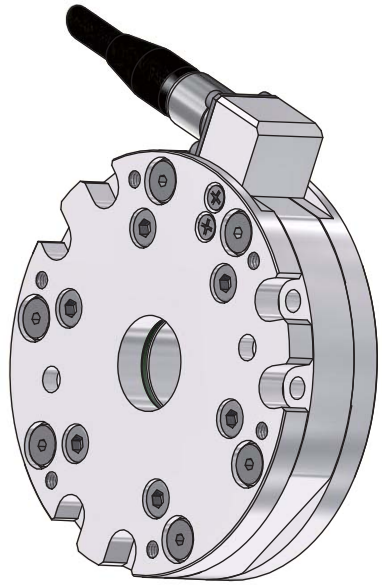

ISOMETRIC VIEW

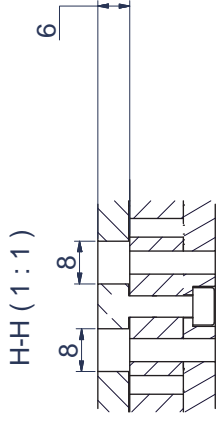

H-H (1:1)

NOTES

1. Do not exceed interface depth, may cause damage.
2. Do not pull on a cable strongly.
3. The housing has been grounded to protect it from external electric noise

PROJECTION	DIMENSION	UNIT
1st Angle		mm

DIMENSIONS

RFT64-6A01

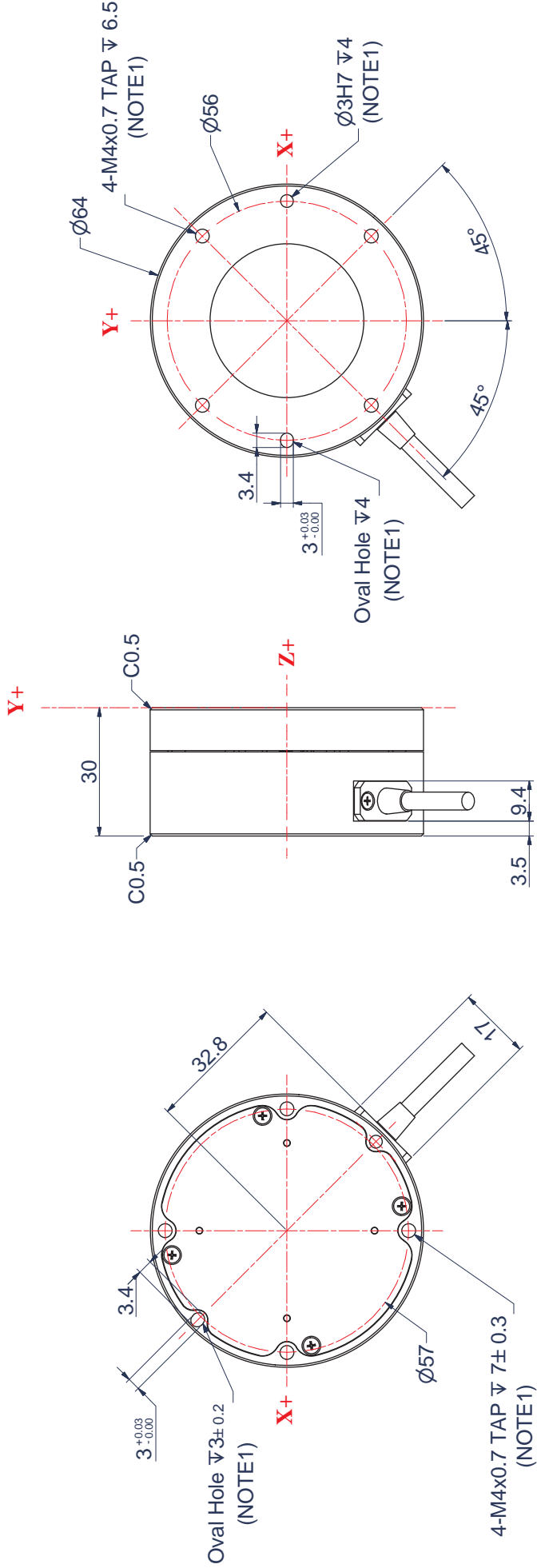

TOP VIEW

SIDE VIEW

BOTTOM VIEW



ISOMETRIC VIEW

NOTES

1. Do not exceed interface depth, may cause damage.
2. Do not pull on a cable strongly.
3. The housing has been grounded to protect it from external electric noise

PROJECTION	1:1
DIMENSION	mm

DIMENSIONS

RFT64-SB01

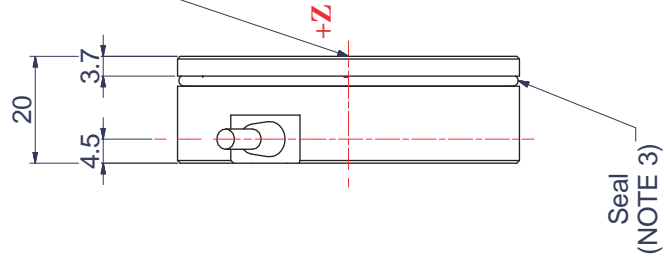
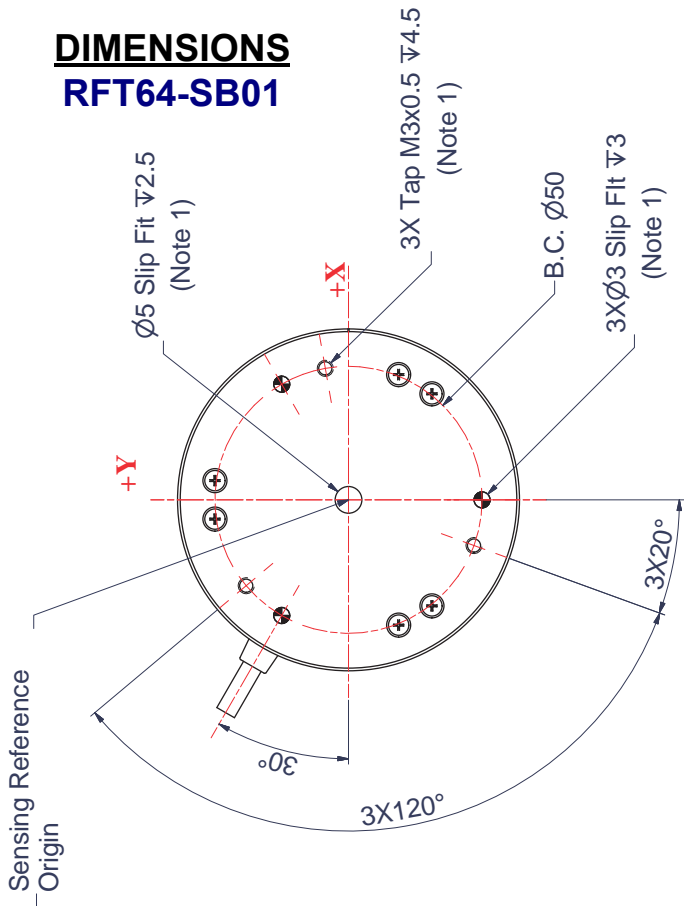

TOP VIEW

SIDE VIEW



ISOMETRIC VIEW

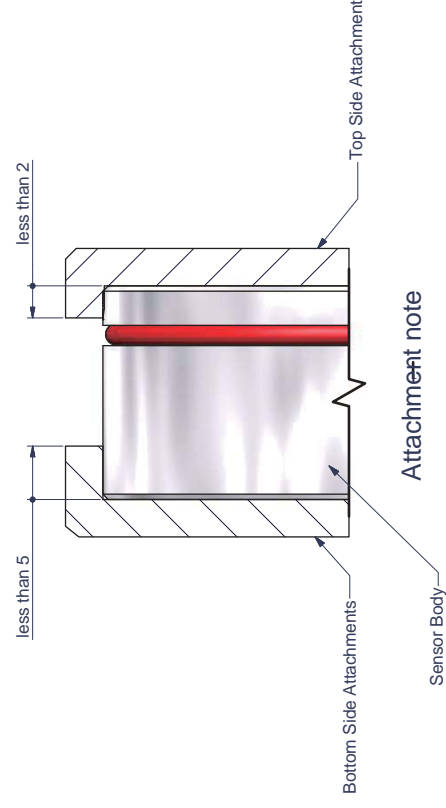

NOTES

1. Do not exceed interface depth, may cause damage.
2. Do not pull on a cable strongly.
3. Do not take off a seal
If seal is taken off, sensor loses the characteristic
4. The housing has been grounded to protect it from external electric noise

PROJECTION DIMENSION	UNIT
	mm

DIMENSIONS

RFT60-HA01

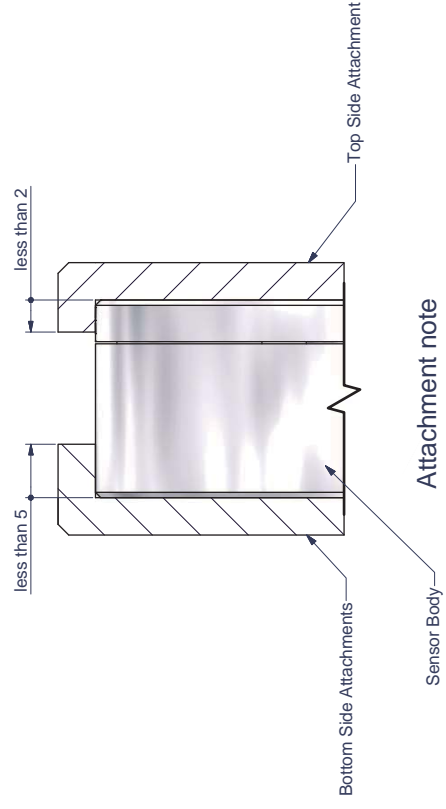
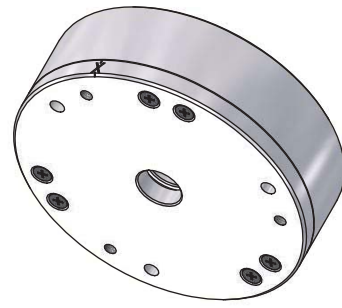
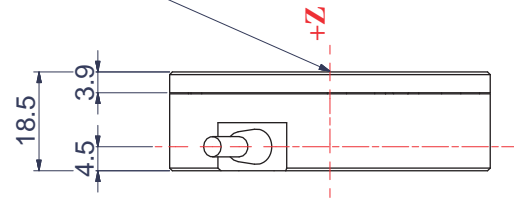
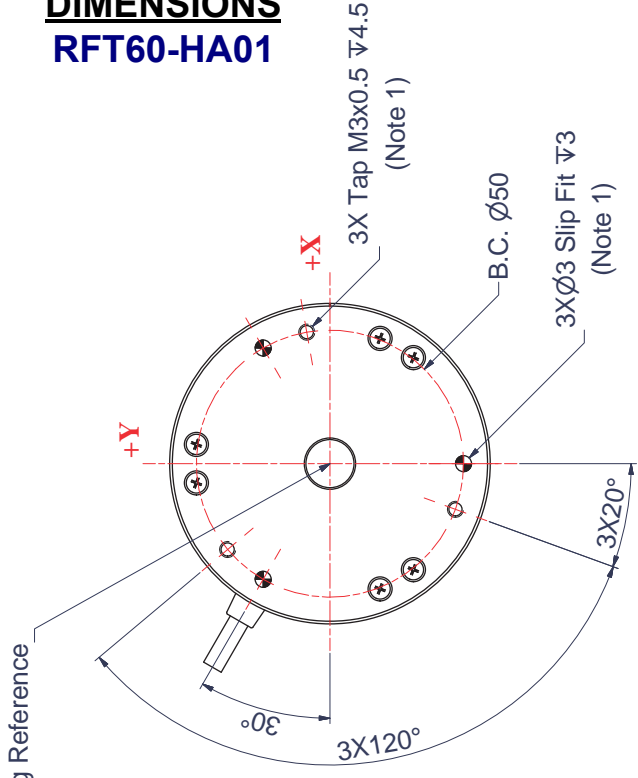

BOTTOM VIEW

TOP VIEW

ISOMETRIC VIEW

NOTES

1. Do not exceed interface depth, may cause damage.
2. Do not pull on a cable strongly.
3. The housing has been grounded to protect it from external electric noise

PROJECTION	DIMENSION	UNIT
		mm

DIMENSIONS

RFT44-SB01

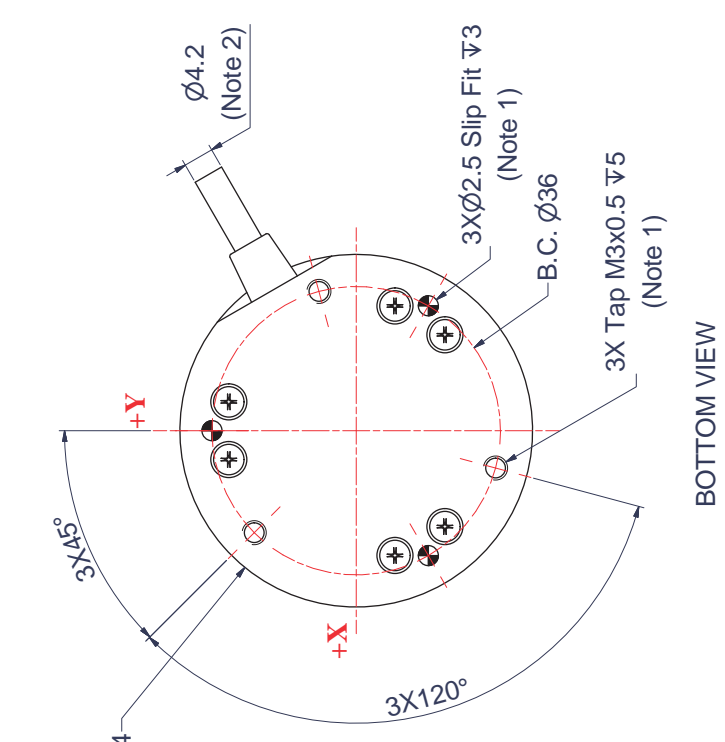
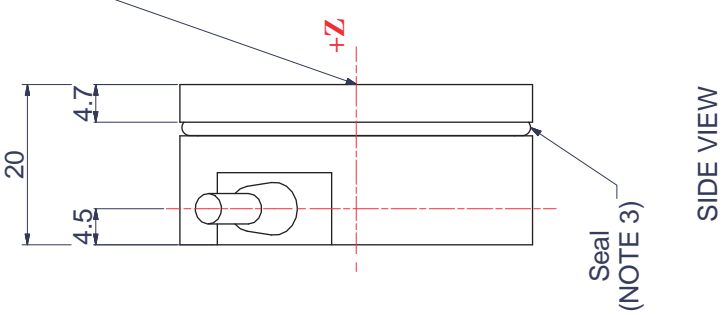
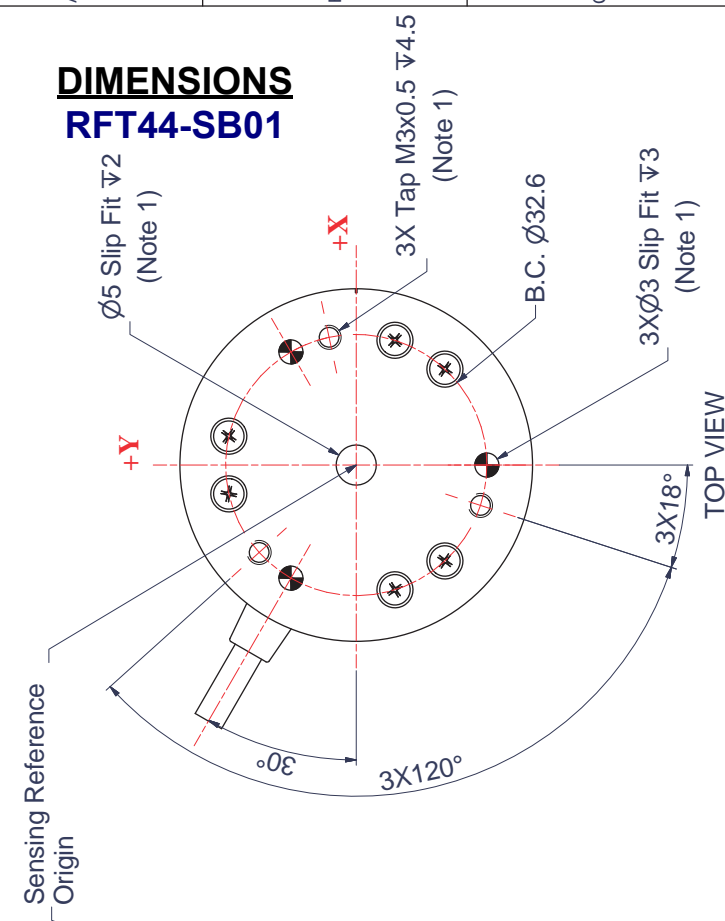

ISOMETRIC VIEW

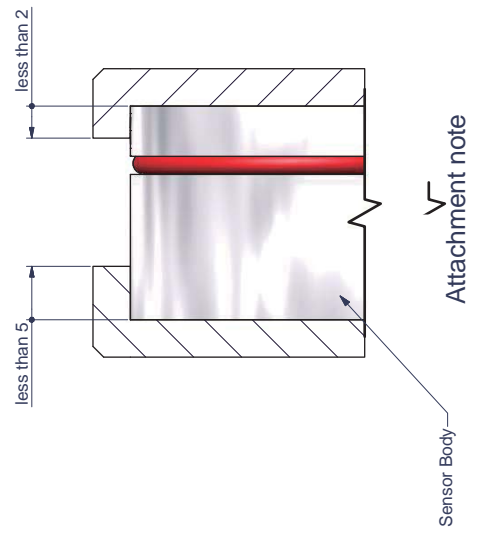

Attachment note

NOTES

1. Do not exceed interface depth, may cause damage.
2. Do not pull on a cable strongly.
3. Do not take off a seal
If seal is taken off, sensor loses the characteristic
4. The housing has been grounded to protect it from external electric noise

PROJECTION	DIMENSION	UNIT
		mm

DIMENSIONS

RFT40-SA01

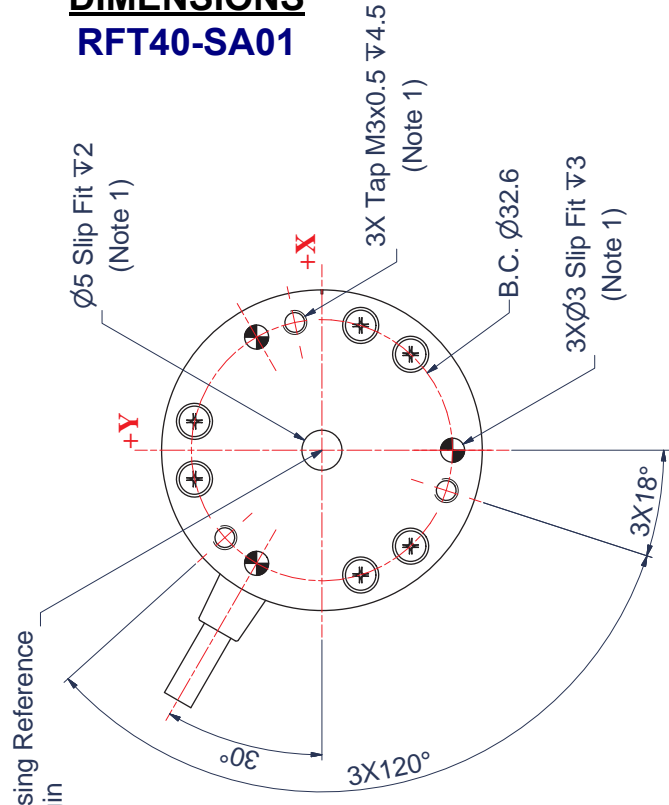

TOP VIEW

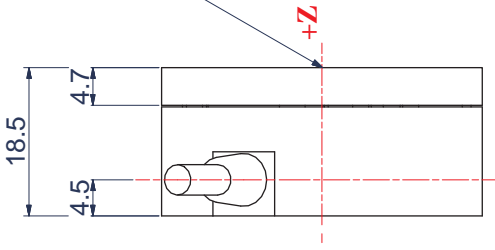

SIDE VIEW

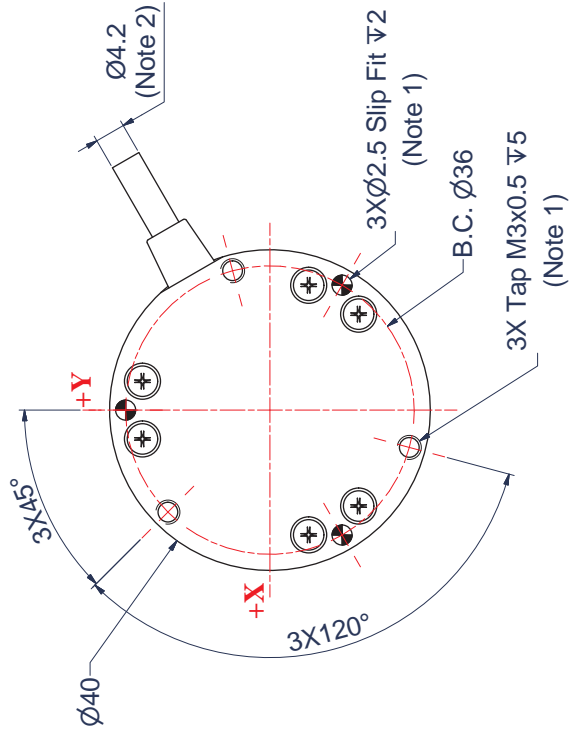

BOTTOM VIEW

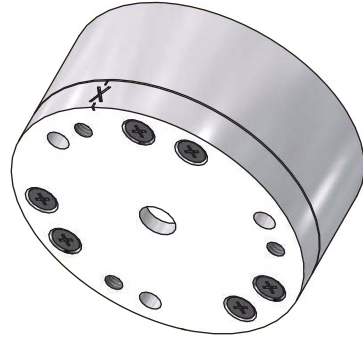

ISOMETRIC VIEW

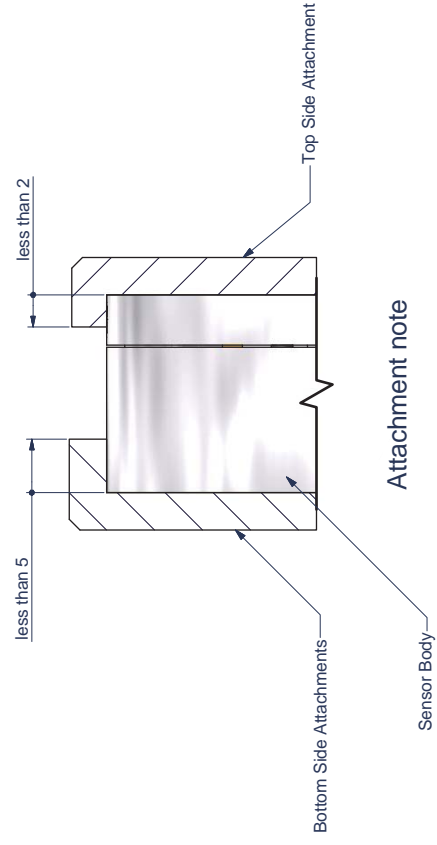

Attachment note

NOTES

1. Do not exceed interface depth, may cause damage.
2. Do not pull on a cable strongly.
3. The housing has been grounded to protect it from external electric noise

PROJECTION	DIMENSION	UNIT
		mm